



Operation Manual Ver. 1.1

SXGA CCD Black & White Camera

Model

PXA130SHP



Primetech Engineering Corp.

Introduction

Thank you for your purchase of the Primetech Engineering product.
We ensure that you will enjoy this and other products from Primetech Engineering for many years.

- Keep this manual and warranty card handy for future reference.

For Safe Use of the Product

To ensure the safe use of this product, carefully read the warnings and cautions provided below prior to use:

| | | |
|---|----------------|--|
|  | Warning | Failure to follow the warning message may result in death or serious injury. |
| | Caution | Failure to follow the caution message may result in injury or property damage. |

Warning – Safety Precautions –

- Never disassemble or modify the product.
- Do not touch the connection cable pins or metal parts with wet hands.
- Do not use the product in a place exposed to rain or water droplets or where toxic gases (liquids) are generated nearby.
- If the product will not be used for an extended period of time, unplug the connection cable from the camera.
- When installing, inspecting or handling the product in a high place, implement sufficient measures beforehand to prevent the device and parts from falling.
- If you see smoke, smell a bad odor or hear an abnormal noise, immediately turn off the power supply and unplug the cable from the product.
- Do not use this product in a system that may cause a serious accident if the product exhibits an abnormality.

Caution – Precautions on Use –

- Use the product within the operating temperature range (-5 to +45°C).
- Use the product at the specified power-supply voltage (+12 VDC).
- Avoid any strong impact or vibration to the product.
- Provide sufficient space around the installed product to prevent the product's internal temperature from rising.
- If the product is used in a dusty environment, be sure to implement dust-protection measures.
- Be sure to turn off the power supply after the cable has been unplugged and then plugged in again with the power on.
- Dust and smudges on the surface of the cover glass will appear as black stains on the image. Blow away any dust with air, etc., and wipe off any smudges using a cotton swab moistened with ethyl alcohol. When cleaning smudges, be careful not to scratch the surface of the cover glass.
- It is recommended to use a daylight-color fluorescent lamp or other light source that is free from infrared light. When using a halogen lamp or other light source containing infrared light, use an infrared cutoff filter.
- Do not share the power supply with a motor or other type of noise-generating device.
- The SG (signal ground) and FG (frame ground) are connected inside the camera. Design the system in such a way as to prevent the looping caused by ground potential difference.

Supplemental Note

- A period of 10 to 20 minutes of aging after turning on the power allows more stable images to be captured.

Disclaimer

Primetech Engineering shall assume no responsibility for the following under any circumstance:

- Loss arising from fire, earthquake, a man-made disaster or an act of God; willful or accidental misuse of the product; or use of the product by a third party in an abnormal manner;
- Loss arising from repair or modification performed by the customer;
- Incidental loss (lost business profit, suspension of business, etc.) arising from the use of or inability to use the product; and
- Loss arising from malfunction, etc., caused by the combined use of connected devices.

Revision History

| Revision | Date of revision | Description of change |
|----------|------------------|-------------------------------|
| 1.0 | 2019/03/14 | Released the initial version. |
| 1.1 | 2020/07/15 | Correction of errors |
| | | |
| | | |
| | | |

Table of Contents

| | |
|---|----|
| 1. Overview | 7 |
| 1.1. Characteristics | 7 |
| 2. System Configuration | 8 |
| 3. Connection Diagram | 9 |
| 4. Specifications of Camera Parts | 10 |
| 4.1. Front/Top/Bottom | 10 |
| 4.2. Rear panel | 11 |
| 4.3. Pin assignment for VIDEO OUT/DC IN/SYNC terminal | 13 |
| 4.4. Input phase specifications for external VD/HD signal | 13 |
| 4.5. WEN output specifications | 13 |
| 4.6. Trigger pulse specifications..... | 14 |
| 5. Frame Rate Setting | 16 |
| 6. Gain Setting | 17 |
| 7. Shutter Speed Setting | 18 |
| 8. Trigger Mode Setting..... | 19 |
| 8.1. Normal Shutter Mode..... | 19 |
| 8.2. Restart Reset Mode | 19 |
| 8.3. External Triggered Shutter Mode | 20 |
| 8.3.1. Mode1 non-reset mode | 20 |
| 8.3.2. Mode2 reset mode | 20 |
| 9. Scanning Mode Setting | 21 |
| 9.1. All Pixels Readout Mode | 21 |
| 9.2. Binning Mode..... | 22 |
| 9.3. High-rate Scanning Mode | 22 |
| 10. Timing Chart Individual Modes..... | 23 |
| 10.1. Restart Reset mode | 23 |
| 10.2. External Triggered Shutter Mode | 24 |
| 10.2.1. Mode1 Non-reset mode | 24 |
| 10.2.1.1. Shutter speed:Trigger pulse width, VD/HD:Input (continuous input) | 24 |
| 10.2.1.2. Shutter speed:VD/HD:DIP switch, VD/HD:Input (continuous input) | 25 |
| 10.2.1.3. Shutter speed:Trigger pulse width, VD/HD:Input(single input) | 26 |
| 10.2.1.4. Shutter speed:DIP switch, VD/HD:Input(single input) | 27 |
| 10.2.1.5. Shutter speed:Trigger pulse width, VD/HD:No input | 28 |
| 10.2.1.6. Shutter speed:DIP switch, VD/HD:No input | 29 |
| 10.2.2. Mode2 Reset mode | 30 |
| 10.2.2.1. Shutter speed:Trigger pulse width | 30 |
| 10.2.2.2. Shutter speed: DIP switch | 31 |
| 11. Video Output Timing Chart..... | 32 |
| 11.1. All Pixels Readout Timing Chart..... | 32 |
| 11.2. Binning Readout Timing Chart | 33 |
| 11.3. 1/2 High-Rate scanning Readout Timing Chart..... | 34 |
| 11.4. 1/4 High-Rate scanning Readout Timing Chart..... | 35 |
| 12. Specifications | 36 |
| 12.1. Relative spectral sensitivity characteristics | 37 |
| 13. External Dimensions..... | 38 |

1. Overview

This operation manual describes functions and procedures for the industrial analog camera (B/W).

1.1. Characteristics

• **Diverse mode setting**

The following settings can be used by toggling the switch on the rear panel.

- Synchronous input/output
- Shutter speed
- Shutter function: Normal/triggered shutter
- 30fps/15fps switchable
- 1/2 High-rate scanning mode
- 1/4 High-rate scanning mode
- Binning Mode
- Gain control
- 75 Ω termination

• **External synchronization**

Depending on a VD or HD signal input, the camera operates with external synchronization.

• **Internal synchronizing signal output**

Synchronizing signals (VD, HD) can be output via the 12-pin connector by toggling the switch on the rear panel.

• **External triggered shutter function**

A still image can be obtained by inputting a trigger. It allows stable capture of an object that moves at high speed.

• **Restart/reset function**

CCD images can be accumulated according to the length between VD pulses by continuously inputting synchronizing signals (VD, HD) from an external device.

It is effective for long-time exposure. (2VD or more)

• **Camera module fixing**

The screw holes for fixing the camera module are located on the lower surface of the front panel that includes the CCD reference plane. Fixing the camera module on the front panel can minimize deviation of the optical axis.

• **Complies with the new 12-pin EIAJ assignment**

2. System Configuration

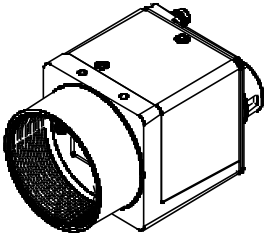

<Video camera module>

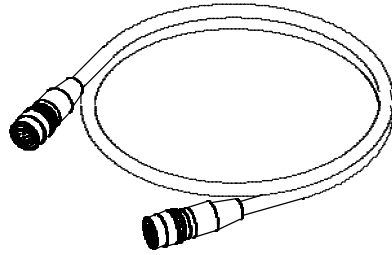

<Camera cable>

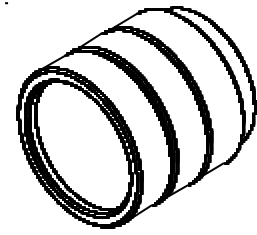

<C-mount lens>

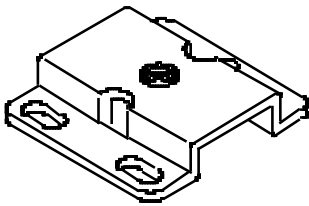

<Tripod adaptor>

3. Connection Diagram

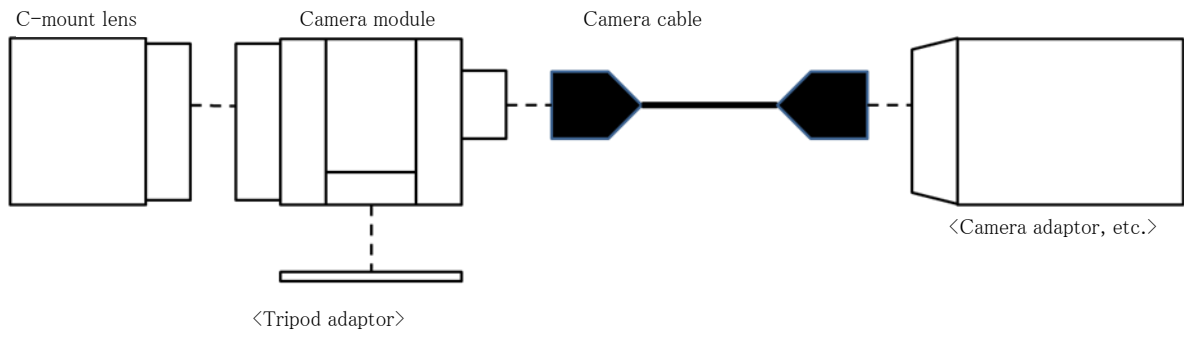

4. Specifications of Camera Parts

4.1. Front/Top/Bottom

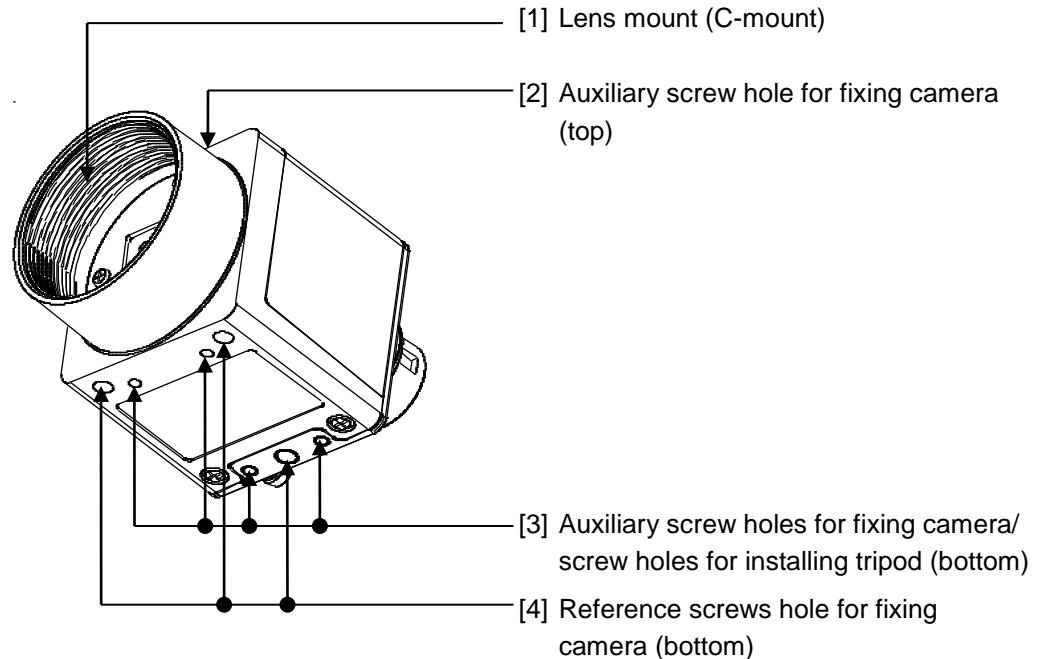

[1] Lens mount (C-mount)

Attach a C-mount lens or other optical equipment.

Caution

Use a C-mount lens that does not project more than 9 mm from the lens mount surface.

Be careful to select the lens to attach the camera, as the resolution of the video output from the camera may differ depending on the lens performance. Moreover, the lens performance may vary depending on the aperture value even with a single lens. When sufficient resolution is not attained, change the aperture value.

[2] Auxiliary screw hole for fixing camera (top)

[3] Auxiliary screw holes for fixing camera/screw holes for installing tripod (bottom)

When using a tripod, use these 4 holes to attach a tripod adaptor.

[4] Reference screw holes for fixing camera (bottom)

These holes are used to fix the camera module. Fix the camera module using these holes to minimize the deviation of the optical axis.

Installing a tripod

Install the tripod adaptor (separately sold) onto the camera module before attaching the module to the tripod.

Use a screw that protrudes from the installation surface by 5 mm maximum (ℓ) and firmly tighten it using a hand driver.

Ensure that the protrusion never exceed 5 mm.

Caution

When installing a tripod adaptor (separately sold), be sure to use the screws provided with the adaptor.

4.2. Rear panel

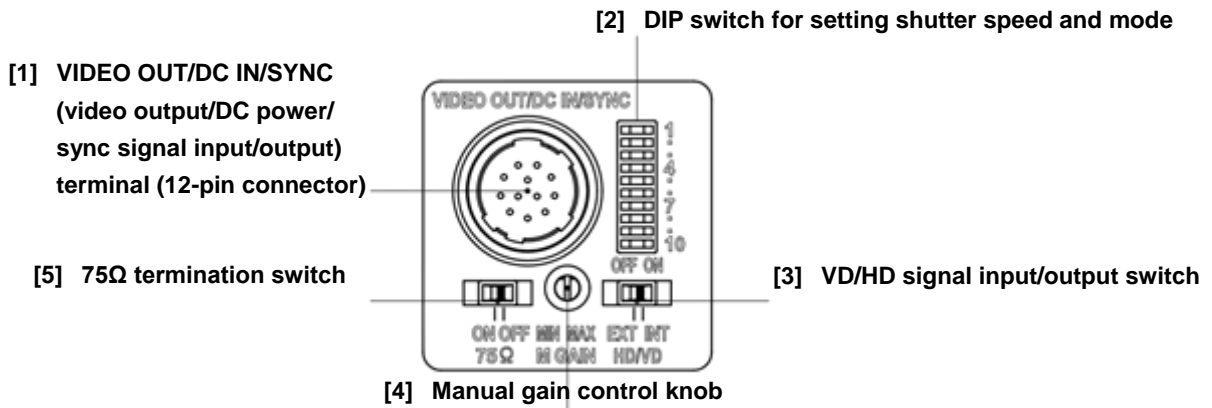

Caution

Turn off the module before setting switches.

[1] VIDEO OUT/DC IN/SYNC (video output/DC power/synchronizing signal input/output) terminal (12-pin connector)
 By connecting a camera cable, the +12V DC power is supplied and a video signal is output from the camera module. When a synchronizing signal generator is connected and an external synchronizing signal (VD/HD signal) is input, the camera module can be operated in synchronization with an external device.

[2] DIP switches for setting shutter speed and mode

- Shutter speed setting (bits 1 to 4)
 Set a shutter speed. The factory setting for the shutter speed is OFF.
- Trigger mode setting (bits 5 to 6)
 Set a Normal shutter mode, Restart reset mode, Non-reset mode, Reset mode. The factory setting for the shutter The factory setting is normal shutter mode.
- Scanning mode setting (bits 7 to 8)
 Set a All pixels readout, Binning, 1/2high-rate scanning, 1/4high-rate scanning. The factory setting is normal shutter mode.
- Gain switch setting (bit 9)
 Set a FIX (fixing) and MANUAL (manual control) modes. The factory setting is FIX.
- Frame rate setting (bit 10)
 Set a 30fps and 15fps. The factory setting is 30fps.

[3] VD/HD signal input/output toggle switch

Set the switch to the INT side to output VD/HD signals, and set it to the EXT side to input VD/HD signals from an external device. The factory setting for the switch is the EXT side.

[4] Manual gain control knob

This knob can be used to adjust the gain when manual adjustment is selected using the gain toggle switch among the DIP switches ([2]).

The factory setting for the knob is Mechanical Center.

[5] 75 Ω termination switch

Set the switch to ON for termination. The factory setting is OFF.

4.3. Pin assignment for VIDEO OUT/DC IN/SYNC (video output/DC power/synchronizing signal input/output) terminal

Rear panel

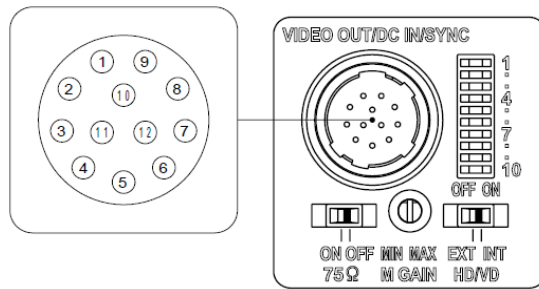

Pin assignment for VIDEO OUT/DC IN/SYNC (Video output/DC power/synchronizing signal input/output) terminal

| Pin No. | Camera synchronizing signal output | External synchronizing signal (VD/HD) | Restart/reset | Externally triggered shutter |
|---------|------------------------------------|---------------------------------------|-----------------------|------------------------------|
| 1 | Ground | Ground | Ground | Ground |
| 2 | +12 VDC | +12 VDC | +12 VDC | +12 VDC |
| 3 | Video output (ground) | Video output (ground) | Video output (ground) | Video output (ground) |
| 4 | Video output (signal) | Video output (signal) | Video output (signal) | Video output (signal) |
| 5 | HD output (ground) | HD input (ground) | HD input (ground) | HD input (ground) |
| 6 | HD output (signal) | HD input (signal) | HD input (signal) | HD input (signal) |
| 7 | VD output (signal) | VD input (signal) | Reset (signal) | VD input (signal) |
| 8 | - | - | - | - |
| 9 | - | - | - | - |
| 10 | WEN output (signal) | WEN output (signal) | WEN output (signal) | WEN output (signal) |
| 11 | - | - | - | Trigger pulse input (signal) |
| 12 | VD output (ground) | VD input (ground) | Reset (ground) | VD input (ground) |

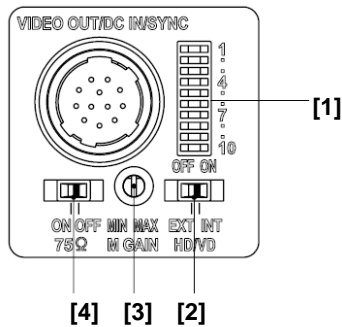

Factory setting mode on the rear panel

| No. | Name of switch | Factory setting mode |
|-----|---|-------------------------------------|
| [1] | DIP switches for setting shutter speed and mode | Shutter speed setting (bits 1 to 4) |
| | | Trigger mode setting (bit 5 to 6) |
| | | Scanning mode setting (bits 7 to 8) |
| | | Gain switch setting (bit 9) |
| | | Frame rate setting (bit 10) |
| [2] | VD/HD signal input/output toggle switch | EXT |
| [3] | Manual gain control knob | Mechanical Center* |
| [4] | 75 Ω termination switch | OFF |

* When the gain toggle switch is set to MGC, the gain is variable within the range from 0 to 18 dB.

4.4. Input phase specifications for external VD/HD signal

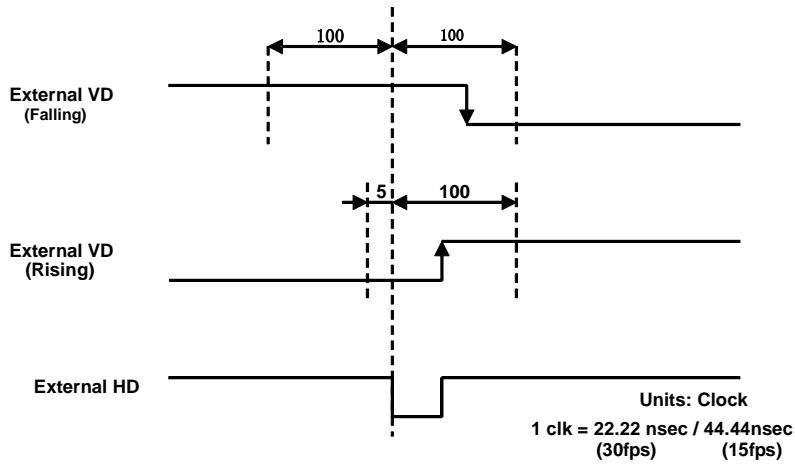

Set the phase relationship for external VD and HD signals as shown in the above figure. Note that inputs other than those specified above can cause unstable internal reset.

For normal shutter mode

Continuous VD/HD signals

For restart/reset mode / non-reset mode / reset mode

Continuous HD signal. Arbitrary timing for VD signal with the phase relationship between VD and HD within the above specifications

4.5. WEN output specifications

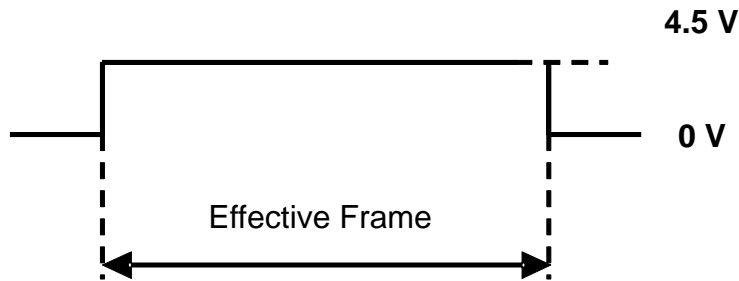

Amplitude levels are representative values when the output terminates at 10 kΩ.

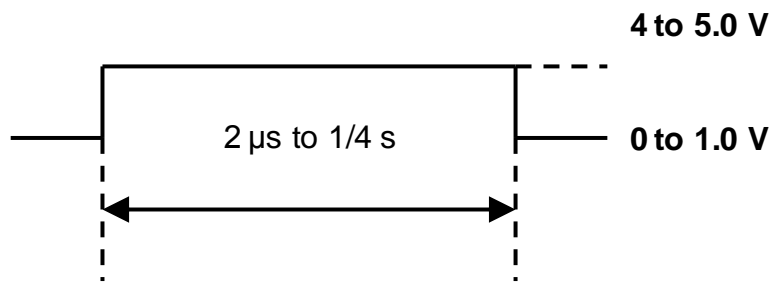

4.6. Trigger pulse specifications





- Input impedance: $10 \text{ k}\Omega$ or more
- Input the pulse width between $100 \mu\text{s}$ and $1/4 \text{ s}$ for DIP switch setting.

Input impedance: Enter the voltage value measured at over $10 \text{ k}\Omega$.

5. Frame Rate Setting

| 30fps mode | 15fps mode |
|--|--|
| 10  | 10  |

6. Gain Setting

| Gain FIX | Gain MANUAL |
|---|---|
| 9  | 9  |

7. Shutter Speed Setting

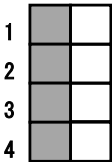
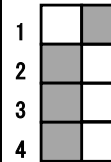
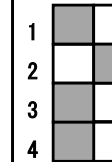
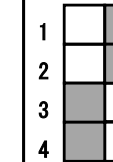
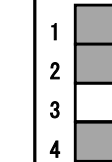
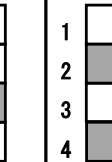
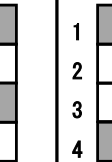
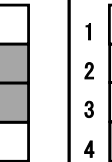
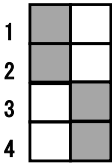
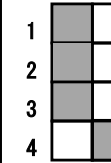







| OFF | 1/125 | 1/250 | 1/500 | 1/1000 | 1/2000 | 1/4000 | 1/10000 |
|---|---|---|---|---|--|---|---|
|  |  |  |  |  |  |  |  |
| 1/20000 | 1/100 | unit : sec | | | | | |
|  |  | | | | | | |

※Shutter speed is at 30fps. Shutter speed will be twice at 15fps.

※Non-reset mode/reset mode is set, shutter OFF will be pulse width trigger shutter.

※Restart reset mode is set, shutter speed setting becomes invalid.

8. Trigger Mode Setting

| Normal shutter mode | Restart reset mode | Non reset mode | Reset mode |
|--|--|--|--|
| 5  6  | 5  6  | 5  6  | 5  6  |

8.1. Normal Shutter Mode

Each scan modes are available. In addition, input and output of VD / HD signals.

8.2. Restart Reset Mode

By inputting restart/reset signals (VD/HD) from an external device, you can obtain information for one screen at an arbitrary timing.

VD enter at intervals of greater than 1V+5H.

Long-time exposure

By extending the CCD accumulation time using the restart/reset function, you can obtain high-sensitivity images. It is useful when sensitivity is insufficient under normal usage conditions, or to observe the tracks of a moving object. To do this, input a VD signal that has a longer period between VD pulses (T in the figure) from an external device.

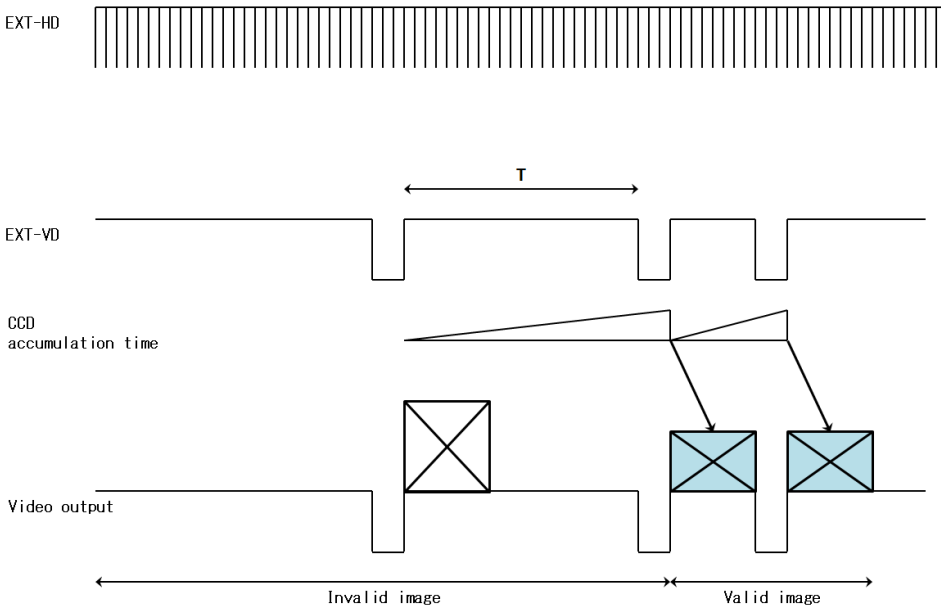

Caution

During long-time exposure, noticeable white flecks may appear.

8.3. External Triggered Shutter Mode

Inputting a trigger from an external device will enable capturing of high-speed moving objects at a correct position. When the trigger pulse width is set to 1/3 s or more, the output is switched to a normal video signal.

8.3.1. Mode1 non-reset mode

By inputting the trigger pulse will enable capturing the image at any time.

By turning OFF the shutter speed setting, it is also possible to set the exposure time in the trigger pulse width.

Also, Inputting the VD/HD from external device will enable external control of image readout.

A video synchronous with the VD signal is output after a trigger input in this mode.

- When an external VD/HD signal is input: The video synchronizes the external VD signal.

- When an external VD/HD signal is not input: The video synchronizes the internal VD signal.

8.3.2. Mode2 reset mode

In this mode, the internal VD signal is reset, and the video is output after a certain period of time has elapsed since a trigger pulse is input.

By turning OFF the shutter speed setting, it is also possible to set the exposure time in the trigger pulse width.

9. Scanning Mode Setting

| All pixels readout mode | Binning mode | 1/2High-rate scanning mode | 1/4High-rate scanning mode |
|-------------------------|--------------|----------------------------|----------------------------|
| | | | |

| Scanning Mode | Frame rate (fps) | Scanning lines (Lines) | Video output lines (Lines) |
|----------------------------|------------------|------------------------|----------------------------|
| All Pixels Readout Mode | 29.99 | 991 | 960 |
| Binning Mode | 60.04 | 495 | 480 |
| 1/2High-rate Scanning Mode | 57.05 | 521 | 480 |
| 1/4High-rate Scanning Mode | 99.07 | 300 | 240 |

※Frame rate is at 30fps. It will be 1/2 at 15fps.

9.1. All Pixels Readout Mode

It is output the signals of all pixels independent from the video output terminal.

9.2. Binning Mode

It is output the signals of 2 pixels vertical mixing from the video output terminal.

9.3. High-rate Scanning Mode

You can increase the frame rate by setting the high-rate scanning mode.

Signal output from the video output terminal is the center of the screen.

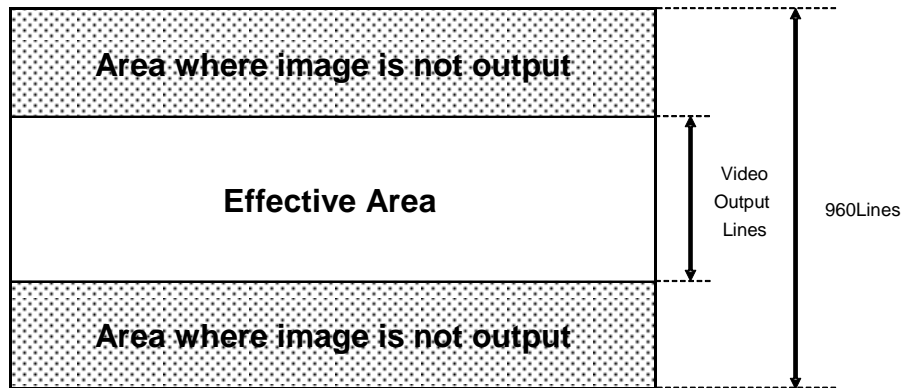

| Scanning Mode | Frame rate (fps) | Scanning lines (Lines) | Video output lines (Lines) |
|----------------------------|------------------|------------------------|----------------------------|
| 1/2High-rate Scanning Mode | 57.05 | 521 | 480 |
| 1/4High-rate Scanning Mode | 99.07 | 300 | 240 |

10. Timing Chart Individual Modes

10.1. Restart Reset mode

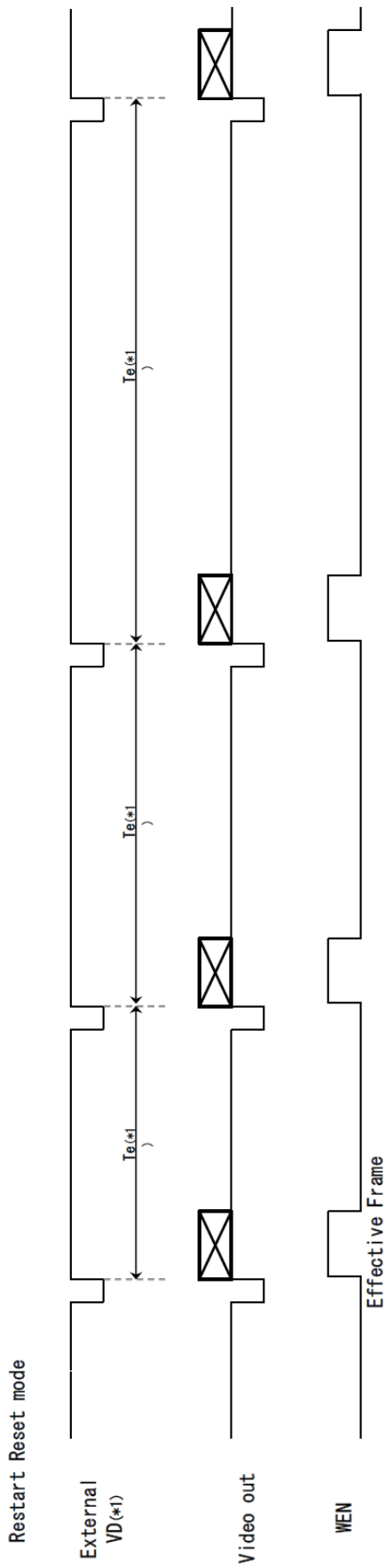

*1 A signal input from an external device.

*2 Shutter speed T_e
Shortest period: 1V+5H

10.2. External Triggered Shutter Mode

10.2.1. Mode1 Non-reset mode

10.2.1.1. Shutter speed: Trigger pulse width, VD/HD: Input (continuous input)

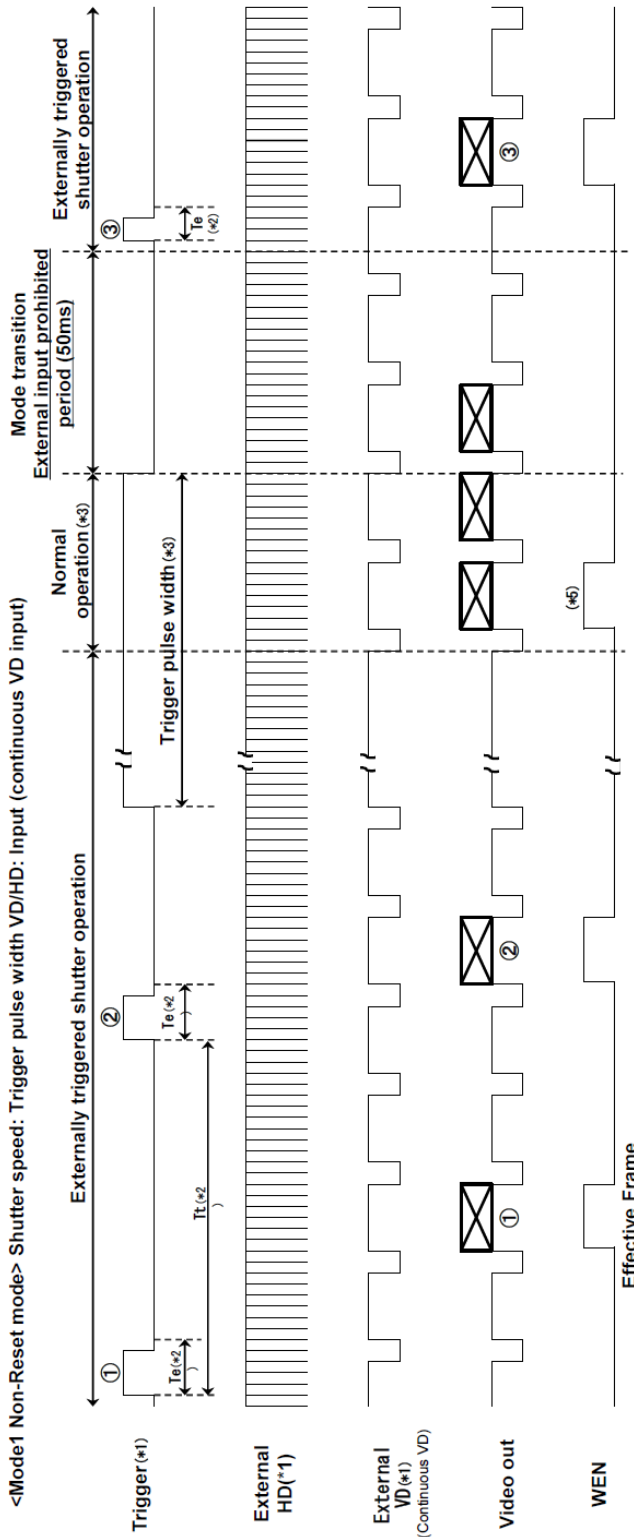

- *1 A signal input from an external device. Always input VD and HD together.
 - *2 Shutter speed T_e / Trigger period T_t
 $T_e =$ Trigger pulse width + 5 μ sec
 (The trigger pulse width valid for an externally triggered shutter operation is 2 μ s to 1/4 s.)
 Shortest trigger period: $T_t =$ Trigger pulse width + 5 μ s + VD wait time + 1V + 2H
 - *3 Setting the trigger pulse width to 1/3 s or more returns to a normal operation. Externally triggered shutter operation resumes upon the falling of the trigger. An input from an external device is prohibited for 50ms after the falling. Therefore, operations related to a trigger input during this period cannot be guaranteed.
 - *4 If the external VD signal falls during the period less than +10 μ s after the falling of the trigger, (1) and [2] in the figure, the output is undefined, that is, a video is output for the latest falling or the next falling of the external VD signal. (The video is output for the next external VD signal in [1] in the figure, and the video is output for the latest external VD signal in [2].) In the above cases, see WEN because it has a one-to-one relationship with the video. In other cases, the video is output for the falling of external VD signals after the falling of the trigger [3] in the figure).
 - *5 After the externally triggered shutter operation has changed to a normal operation, one WEN pulse is output.
- Caution**
 If the next trigger is input before the video output corresponding to the current trigger has finished, the video is affected.

10.2.1.2. Shutter speed:VD/HD:DIP switch, VD/HD:Input (continuous input)

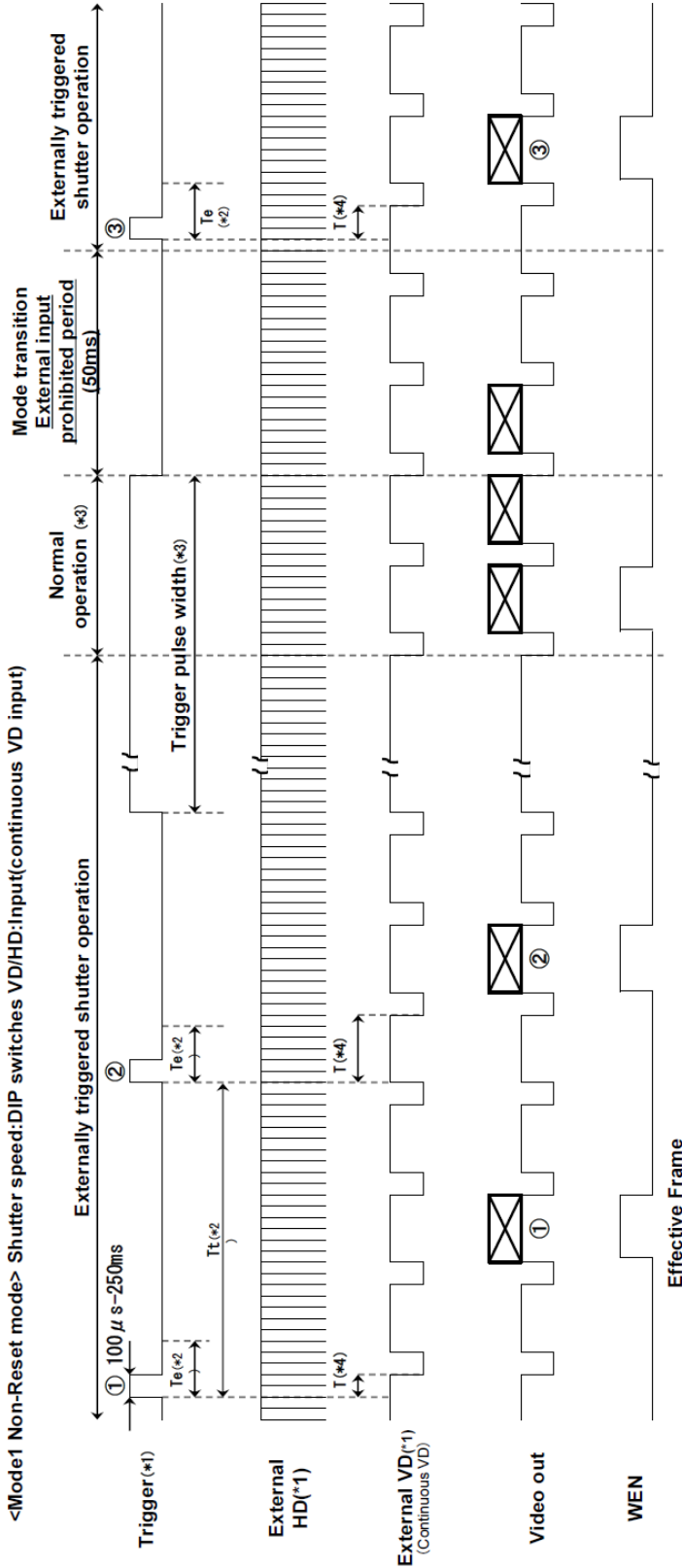

- *1 A signal input from an external device. Always input VD and HD together.
 - *2 Shutter speed T_e / Trigger period T_t
 $T_e = \text{DIP switches setting}$
 $\text{Shortest trigger period } T_t = \text{DIP switches Exposure time setting} + \text{VD wait time} + 1V + 2H$
 - *3 Setting the trigger pulse width to 1/3 s or more returns to a normal operation.
 Externally triggered shutter operation resumes upon the falling of the trigger.
 An input from an external device is prohibited for 50 ms after the falling.
 Therefore, operations related to a trigger input during this period cannot be guaranteed.
 - *4 A video is output for the falling of the external VD signal 20 ms or more after the rising of the trigger. ([2] and [3] in the figure) If the period (T in the figure) from the rising of the trigger to the falling of the external VD signal is less than 20 ms, the output is undefined, that is, a video is output for the latest falling or the next falling of the external VD signal. (In the above case, the video for the next external VD signal is output.)
 In the above case, see WEN because it has a one-to-one relationship with the video.
 - *5 After the externally triggered shutter operation has changed to a normal operation,
- Caution**
 If the next trigger is input before the video output corresponding to the current trigger has finished, the video is affected.

10.2.1.3. Shutter speed: Trigger pulse width, VD/HD:Input(single input)

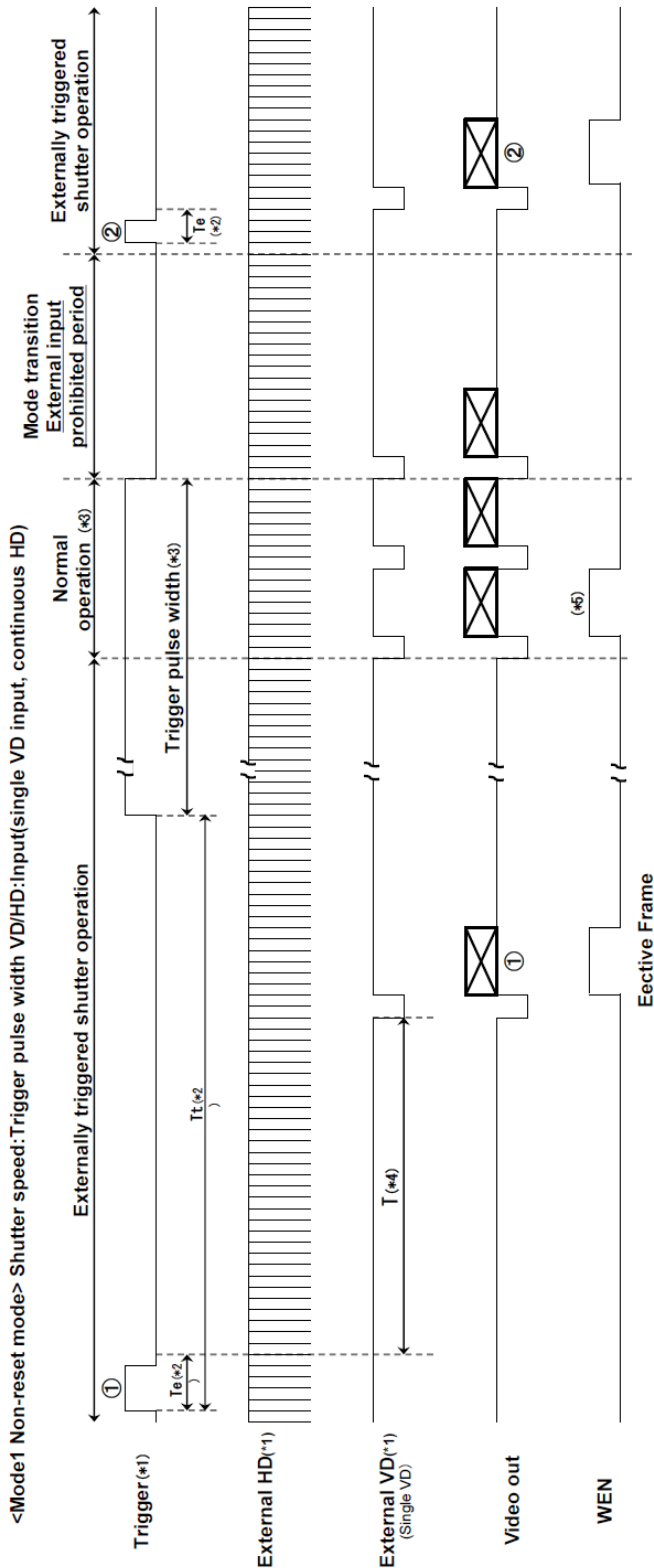

- *1 A signal input from an external device. Always input VD and HD signals together. Input the phase of the VD signal at the rising of the HD signal.
 - *2 Shutter speed T_e / Trigger period T_t
 $T_e = \text{Trigger pulse width} + 5 \mu\text{sec}$
 (The trigger pulse width valid for an externally triggered shutter operation is $2 \mu\text{s}$ to $1/4 \text{ s.}$)
 Shortest trigger period: $T_t = \text{Trigger pulse width} + 5 \mu\text{s} + \text{VD wait time} + 1V + 2H$
 - *3 Setting the trigger pulse width to $1/3 \text{ s}$ or more returns to a normal operation. Externally triggered shutter operation resumes upon the falling of the trigger. An input from an external device is prohibited for $1V$ ms after the falling. Therefore, operations related to a trigger input during this period cannot be guaranteed.
 - *4 Always input an external VD signal $10 \mu\text{s}$ to 65 ms after the falling of the trigger. ([1] and [2] in the figure)
 Operations after inputs under conditions other than the above cannot be guaranteed. Should a value outside the standard range be input, input the signals according to the specified conditions. Normal operation resumes after a few Vs.
 - *5 After the externally triggered shutter operation has changed to a normal operation, one WEN pulse is output.
- Caution**
 If the next trigger is input before the video output corresponding to the current trigger has finished, the video is affected.
 Always input one VD for one trigger.

10.2.1.4. Shutter speed:DIP switches VD/HD:Input(single input)

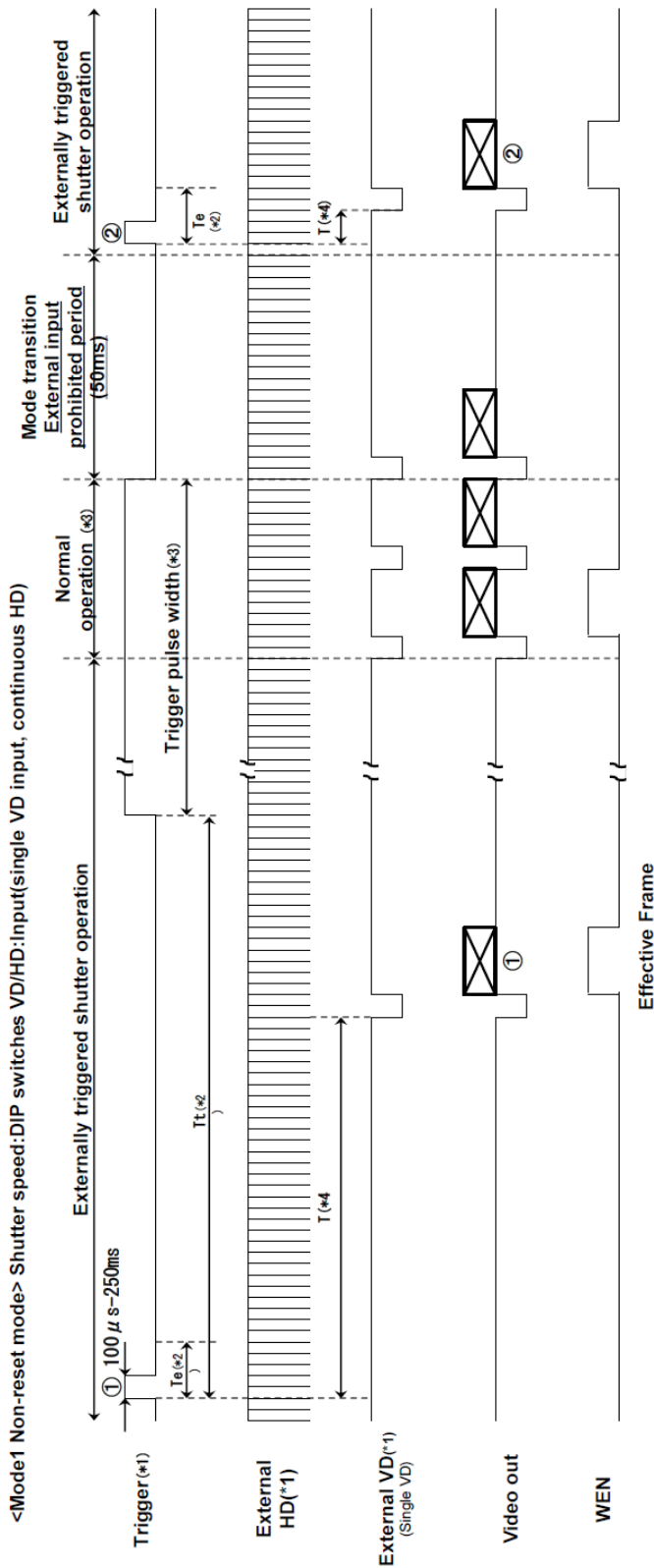

- *1 A signal input from an external device. Always input VD and HD signals together. Input the phase of the VD signal at the rising of the HD signal.
 - *2 Shutter speed Tt / Trigger period T
 $T_e =$ DIP switches setting
 Shortest trigger period $T =$ DIP switches Exposure time setting + VD wait time + $1V + 2H$
 - *3 Setting the trigger pulse width to 1/3 s or more returns to a normal operation. Externally triggered shutter operation resumes upon the falling of the trigger. An input from an external device is prohibited for 1V ms after the falling. Therefore, operations related to a trigger input during this period cannot be guaranteed.
 - *4 Always input an external VD signal 10 μs to 65 ms after the falling of the trigger. ([1] and [2] in the figure)
 Operations after inputs under conditions other than the above cannot be guaranteed. Should a value outside the standard range be input, input the signals according to the specified conditions. Normal operation resumes after a few Vs.
 - *5 After the externally triggered shutter operation has changed to a normal operation, one WEN pulse is output.
- Caution**
 If the next trigger is input before the video output corresponding to the current trigger has finished, the video is affected.
 Always input one VD for one trigger.

10.2.1.5. Shutter speed: Trigger pulse width, VD/HD: No input

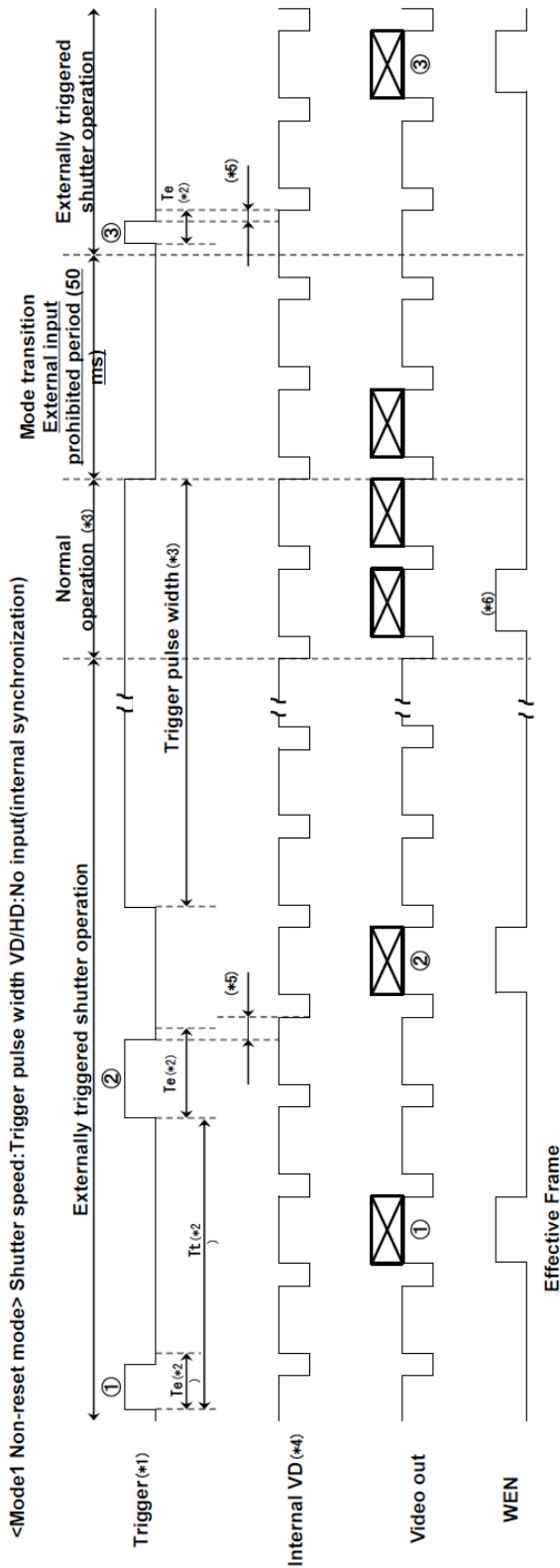

- *1 A signal input from an external device.
 - *2 Shutter speed T_e / Trigger period T_t
 $T_e = \text{Trigger pulse width} + 5 \mu\text{sec}$
 (The trigger pulse width valid for an externally triggered shutter operation is $2 \mu\text{s}$ to $1/4 \text{ s}$.)
 Shortest trigger period: $T_t = \text{Trigger pulse width} + 5 \mu\text{s} + \text{VD wait time} + 1V + 2H$
 - *3 Setting the trigger pulse width to $1/3 \text{ s}$ or more returns to a normal operation. Externally triggered shutter operation resumes upon the falling of the trigger. An input from an external device is prohibited for 50 ms after the falling. Therefore, operations related to a trigger input during this period cannot be guaranteed.
 - *4 Internal VD is output by setting the VD/HD signal input/output toggle switch on the rear panel to the INT side, only when an input from an external device is disabled.
 - *5 In an externally triggered shutter operation, the video is output for the falling of the internal VD signal after the rising of the trigger. ([1] and [2] in the figure) If the period (T in the figure) is undefined, that is, a video is output for the latest falling or the next falling of the internal VD signal. (In [3] in the figure, the video for the next internal VD signal is output.) In the above case, see WEN because it has a one-to-one relationship with the video. (The falling of the internal VD signal and the start of equivalent pulses for the V period are in the same phase.)
 - *6 After the externally triggered shutter operation has changed to a normal operation, one WEN pulse is output.
- Caution**
 If the next trigger is input before the video output corresponding to the current trigger has finished, the video is affected.

10.2.1.6. Shutter speed:DIP switch, VD/HD:No input

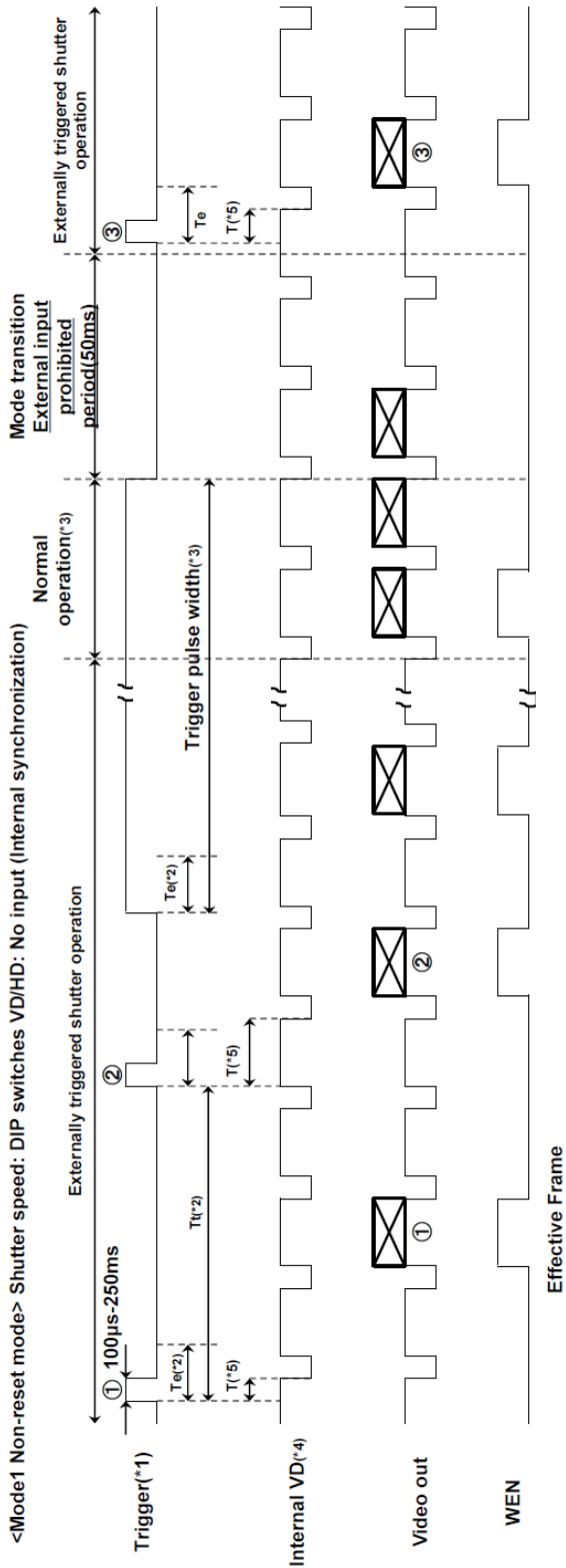

*1 A signal input from an external device.

*2 Shutter speed T_e / Trigger period T_t
 $T_e =$ DIP switches setting
 Shortest trigger period $T =$ DIP switches Exposure time setting + VD wait time + 1V + 2H

*3 Setting the trigger pulse width to 1/3 s or more returns to a normal operation. Externally triggered shutter operation resumes upon the falling of the trigger. An input from an external device is prohibited for 1V ms after the falling. Therefore, operations related to a trigger input during this period cannot be guaranteed.

*4 Internal VD is output by setting the VD/HD signal input/output toggle switch on the rear panel to the INT side, only when an input from an external device is disabled.

*5 A video is output for the falling of the external VD signal 20 ms or more after the rising of the trigger. ([2] and [3] in the figure) If the period (T in the figure) from the rising of the trigger to the falling of the Internal VD signal is less than 20 ms, the output is undefined, that is, a video is output for the latest falling or the next falling of the internal VD signal. (In the above case, the video for the next internal VD signal is output.) In the above case, see WEN because it has a one-to-one relationship with the video.

*6 After the externally triggered shutter operation has changed to a normal operation, one WEN pulse is output.

Caution

If the next trigger is input before the video output corresponding to the current trigger has finished, the video is affected.

10.2.2. Mode2 Reset mode

10.2.2.1. Shutter speed: Trigger pulse width

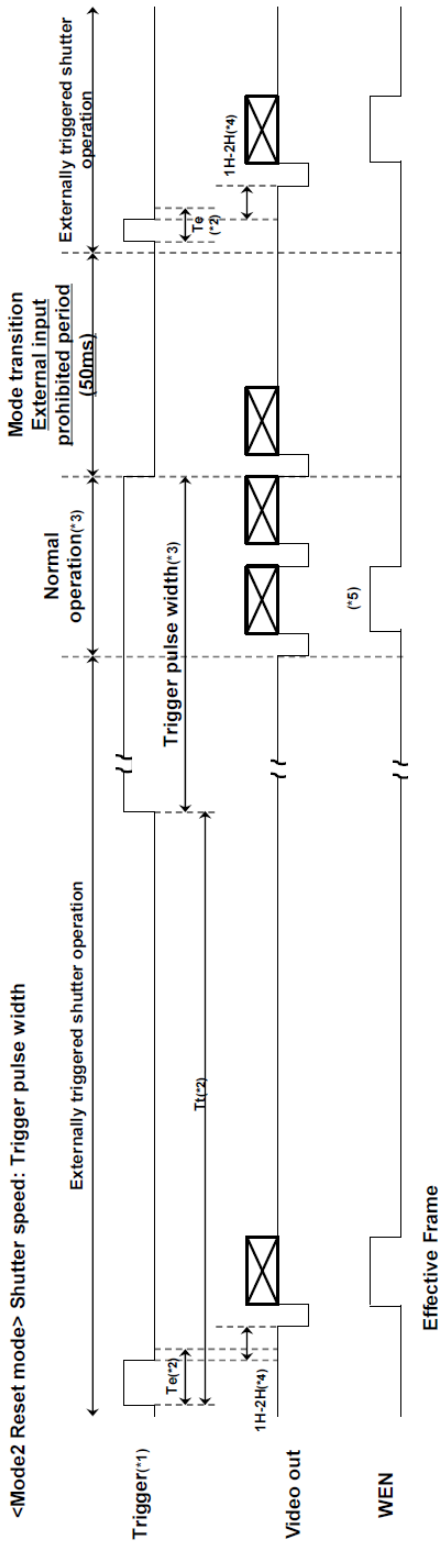

*1 A signal input from an external device

*2 Shutter speed T_e / Trigger period T_t
 $T_e = \text{Trigger pulse width} + 5 \mu\text{sec}$
 (The trigger pulse width valid for an externally triggered shutter operation is $2 \mu\text{s}$ to $1/4 \text{ s}$.)
 Shortest trigger period: $T_t = 1V+5H$

*3 Setting the trigger pulse width to $1/3 \text{ s}$ or more returns to a normal operation. Externally triggered shutter operation resumes upon the falling of the trigger. An input from an external device is prohibited for $1V$ ms after the falling. Therefore, operations related to a trigger input during this period cannot be

*4 A VD signal is generated $1H$ to $2H$ after the falling of the trigger and a video is output in synchronization.

*5 After the externally triggered shutter operation has changed to a normal operation, one WEN pulse is output.

10.2.2.2. Shutter speed: DIP switch

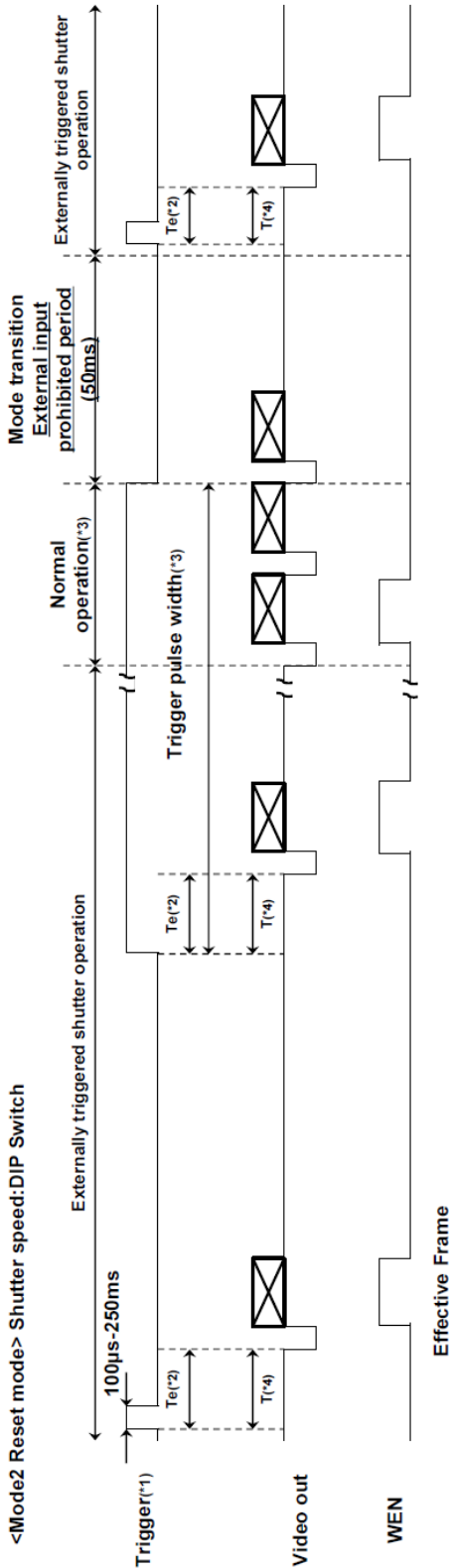

*4 A video is output at the shortest timing after the trigger, according to the setting of the DIP switches.

*5 After the externally triggered shutter operation has changed to a normal operation, one WEN pulse is output.

*1 A signal input from an external device

*2 Shutter speed T_e / Trigger period T_t
 T_e = DIP switch setting
 Shortest trigger period: $T_t = 1V+5H$

*3 Setting the trigger pulse width to 1/3 s or more returns to a normal operation. Externally triggered shutter operation resumes upon the falling of the trigger. An input from an external device is prohibited for 50 ms after the falling. Therefore, operations related to a trigger input during this period cannot be guaranteed.

11. Video Output Timing Chart

11.1. All Pixels Readout Timing Chart

The horizontal timing chart at 30 fps setting is shown below.

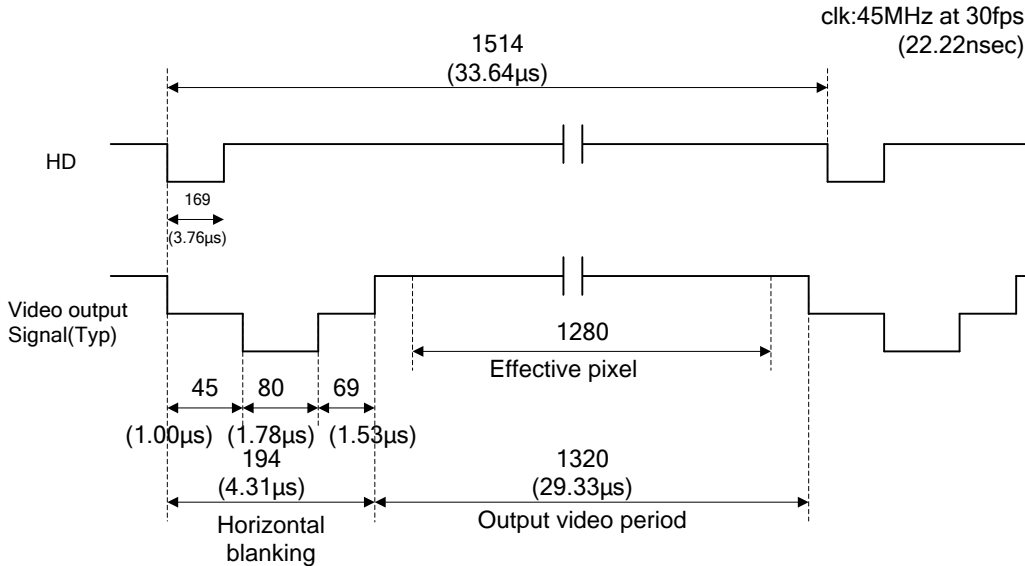

※A unitless number represents the number of clock counts.

※At 15 fps setting, clk is 22.5 MHz and time is doubled.

The vertical timing chart at 30 fps setting is shown below.

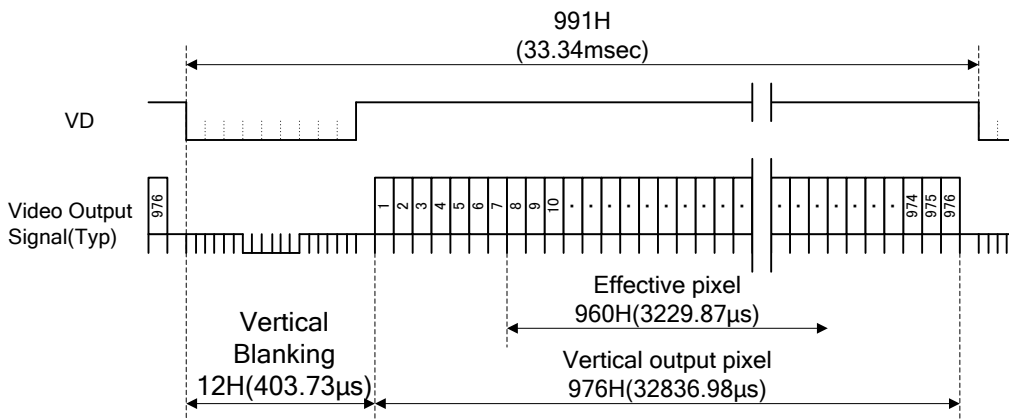

※At 15 fps setting, time is doubled.

11.2. Binning Readout Timing Chart

The horizontal timing chart at 30 fps setting is shown below.

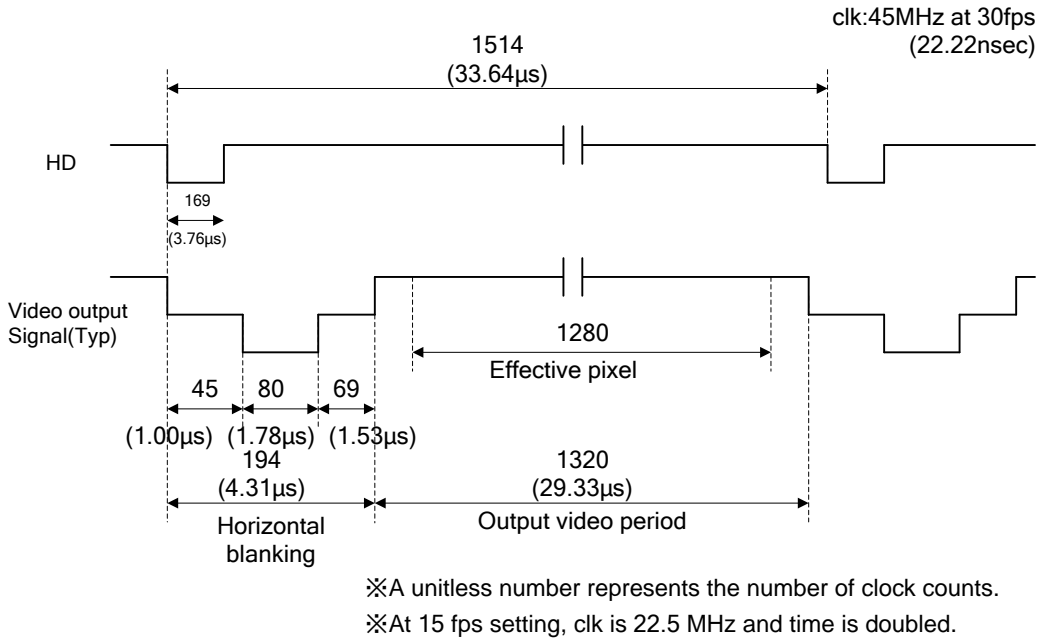

The vertical timing chart at 30 fps setting is shown below.

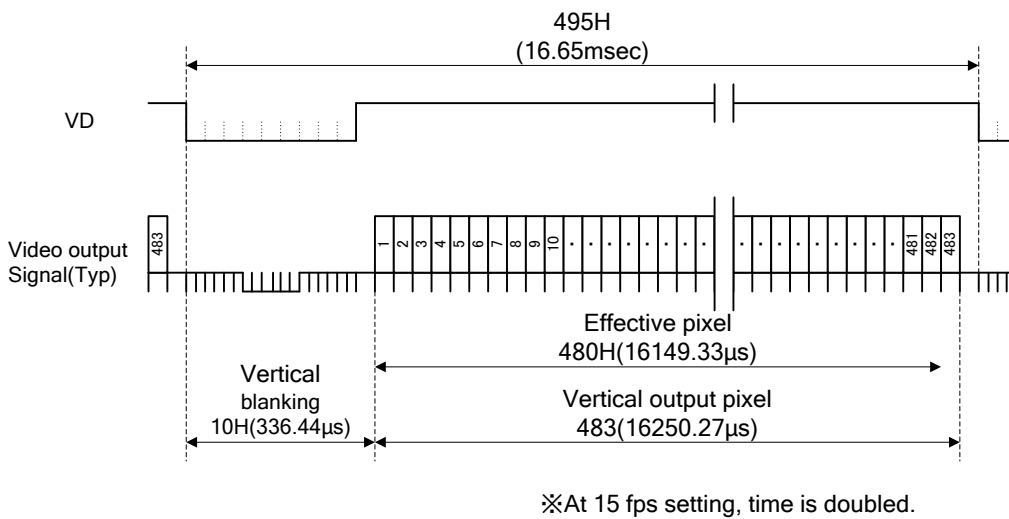

11.3. 1/2 High-rate Scanning Readout Timing Chart.

The horizontal timing chart at 30 fps setting is shown below.

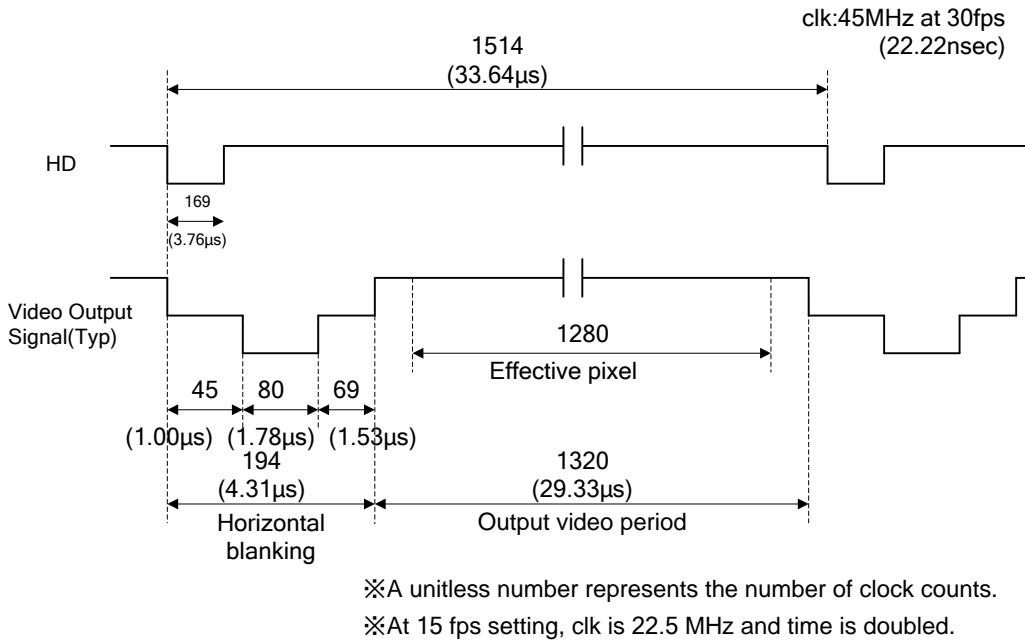

The vertical timing chart at 30 fps setting is shown below.

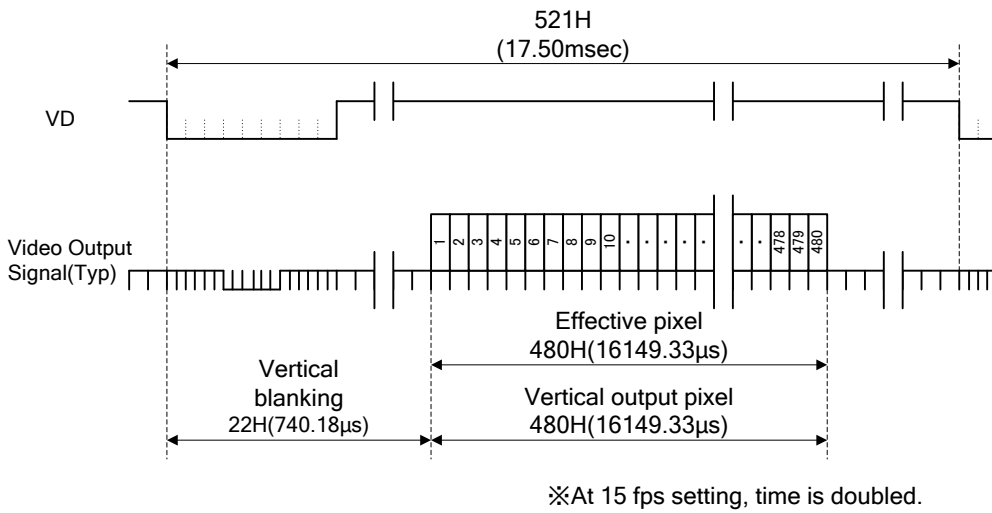

11.4. 1/4 High-Rate scanning Readout Timing Chart.

The horizontal timing chart at 30 fps setting is shown below.

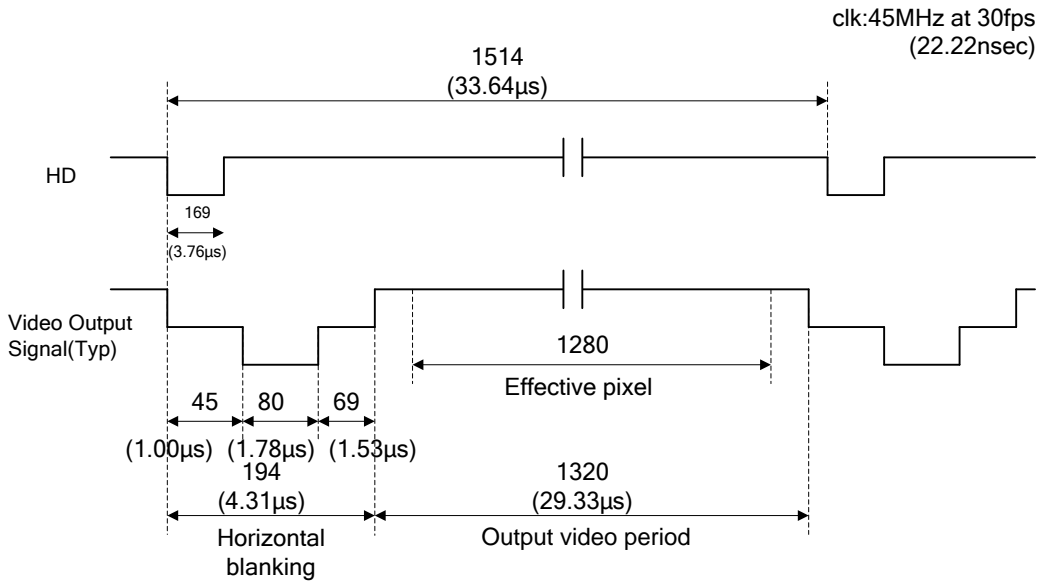

※A unitless number represents the number of clock counts.
 ※At 15 fps setting, clk is 22.5 MHz and time is doubled.

The vertical timing chart at 30 fps setting is shown below.

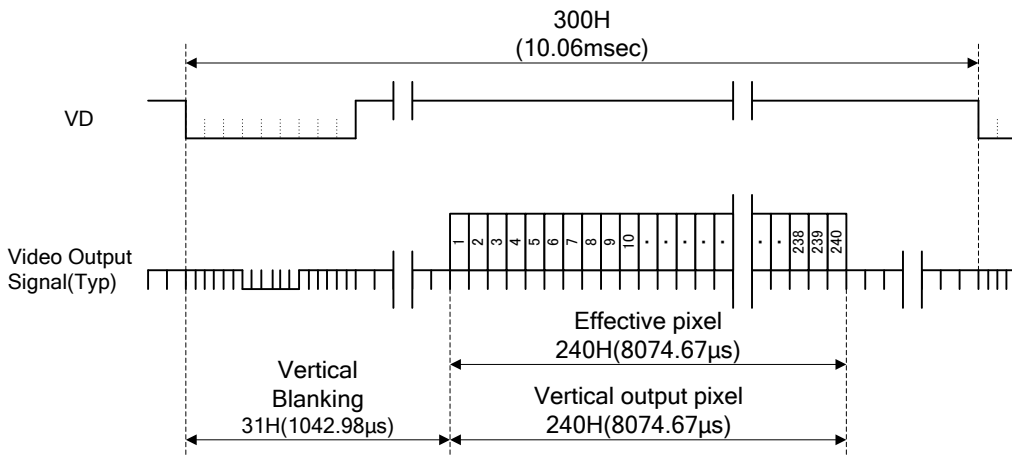

※At 15 fps setting, time is doubled.

12. Specifications

| | |
|--|--|
| Pickup device | Interline transfer 1/3 type CCD |
| Effective picture elements | 1280 × 960 (horizontal/vertical) |
| CCD vertical driving frequency | 29.723kHz (at 30fps) / 14.861kHz(at 15fps) |
| CCD horizontal driving frequency | 45.0000MHz(at 30fps) / 22.5000MHz(at 15fps) |
| Signaling | – |
| Cell size | 3.75 × 3.75 μm (horizontal/vertical) |
| Lens mount | C-mount |
| Flange focus | 17.526 ±0.05 mm |
| Synchronization | External synchronization / Internal synchronization |
| External synchronization input/output | VD/HD (1 Vp-p) |
| Allowable external synchronization frequency deviation | ±1% (of horizontal synchronization frequency) |
| Jitter | ±50 ns or less |
| Scanning method | Non-interlace |
| Sensitivity | 400 lx (F5.6, shutter:OFF, Manual gain:Min) |
| S/N ratio | 56dB |
| Minimum illumination | 1 lx (with the manual gain control at maximum, F1.4) |
| Gain | MGC / FIX |
| Gamma correction | – |
| Shutter function | External trigger shutter |
| Shutter speed | External trigger shutter: 2 μs to 1/4 s |
| Power | DC +12V |
| Power consumption | Approx. 1.80 W |
| Operating temperature | –5 to +45°C |
| Operating relative humidity | 20 to 80% (no condensation) |
| Storage temperature | –30 to +60°C |
| Storage relative humidity | 20 to 95% (no condensation) |
| Vibration resistance | 10 G (20 Hz to 200 Hz) |
| Shock resistance | 70 G |
| External dimensions | W 29 mm × H 29 mm × D 29 mm (connectors excluded) |
| Weight | Approx.48 g |
| Standards | CE, FCC |
| Accessories | Lens mount cap (1), Operation Manual (1) |

Specifications and design are subject to change without notice.

12.1. Relative spectral sensitivity characteristics

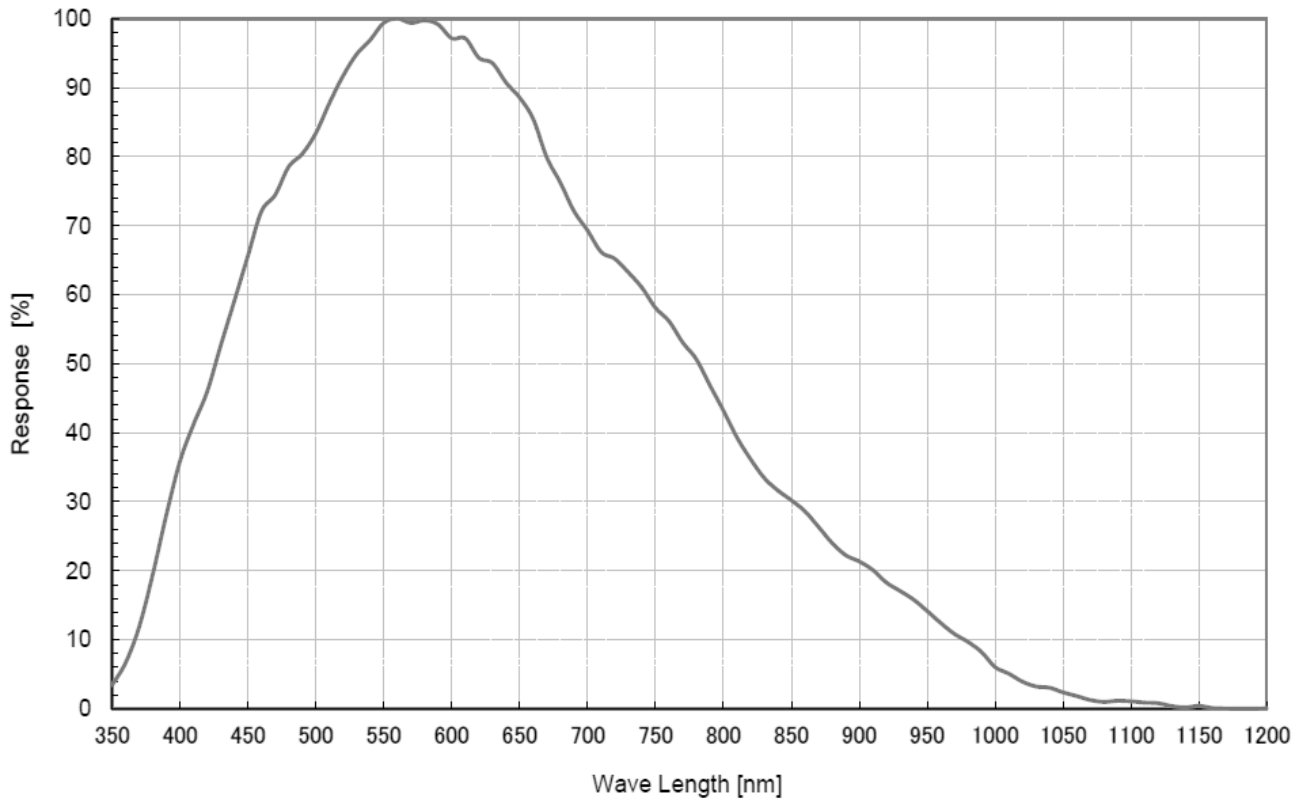

13. External Dimensions

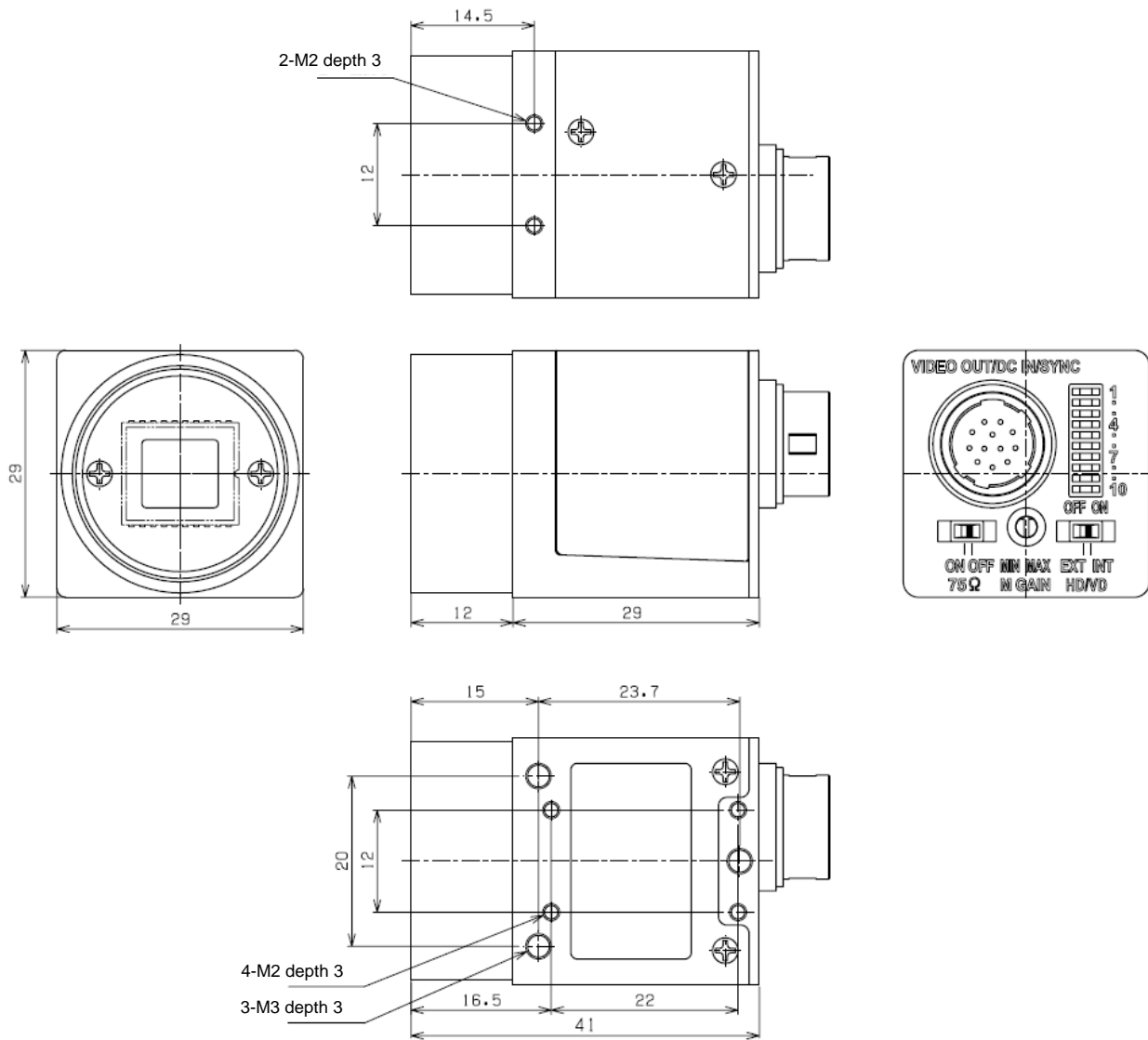

Units: mm

The content of this manual is subject to change without notice.

Technical materials and data in this manual are only for reference of actual use. Nothing contained herein shall be construed as granting the rights to practice or use the intellectual properties of our company or any other third party.

Thus we assume no responsibility whatsoever for any violation resulting from such use.

Contact:

Primetech Engineering Corp.
1-3-25, Koishikawa, Bunkyo-ku,
Tokyo 112-0002
Tel. 03-5805-6766
Fax. 03-5805-6767
URL: <http://www.pte.jp>
Mail: sales@pte.co.jp